



특징 (Character)

- 링크레버를 이용 실린더의 추력확대로 우수한 파지력
Great gripping force by link lever
- $\Phi 16 \sim \Phi 100$ 까지 풍부한 기종보유로 선택의 폭이 다양
Wide and various selection possible by various size
- 링크레버 타입의 원형몸체구조의 그리퍼
Link lever type gripper by the cylindrical structure
- 2,3,4 JAW의 다양한 모델
Various type by 2,3,4 jaw
- 개폐검출용 마그네틱 센서 부착가능
Magnetic sensor is available for open-close sensing



링크레버 방식 (Link lever type)

작동 방식 (Kinetics)

링크레버 방식
Great gripping force
by link lever

조 (Jaws)

파지부
for gripping

몸체 (Body)

경질 처리된 경량의
알루미늄 합금
high-tensile aluminum body with
lightest possible because of
hard anodizing

정밀한 T형 가이드 (Precise flat guide)

높은 힘과 고강성
guide a long entire length of
housing. very high force and
moment absorption

구동부 (Drive)

복동식
double acting
pneumatic cylinder

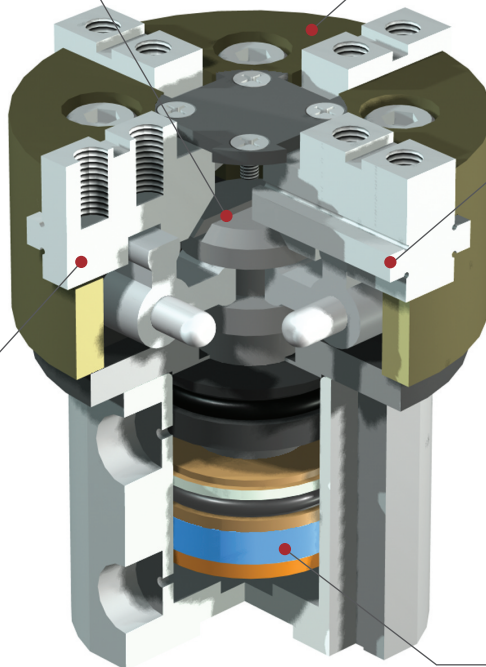

부품분해도 (Exploded view)

※ 본 분해도는 한 제품을 예시하였으므로 기종별로 차이가 있을 수 있습니다
 ※ This is exploded view illustrates a certain product only. The contents may vary by product models.

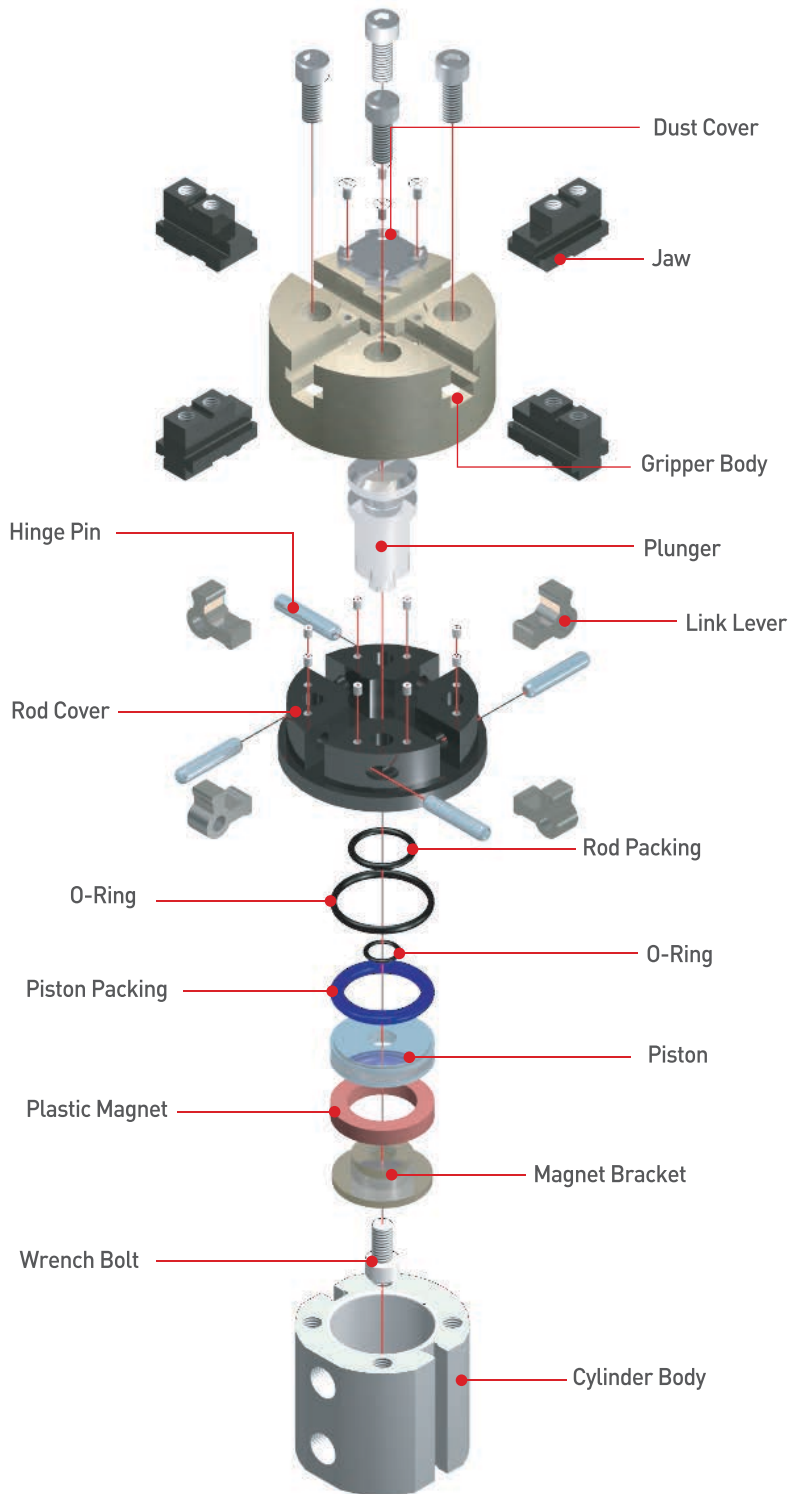

- AF101
- AF02
- AF03
- AF04P
- AF105P
- AF06
- AF10
- AF13
- AF13C
- AF14
- AF15
- AF316
- AF17
- AF117
- AF19
- AF24
- AF26**
- AF28D
- AF30
- AF30L
- AF30SP
- AF40
- AF46
- AF56N
- RAF56N
- MF16

주문기호 (Ordering Code)

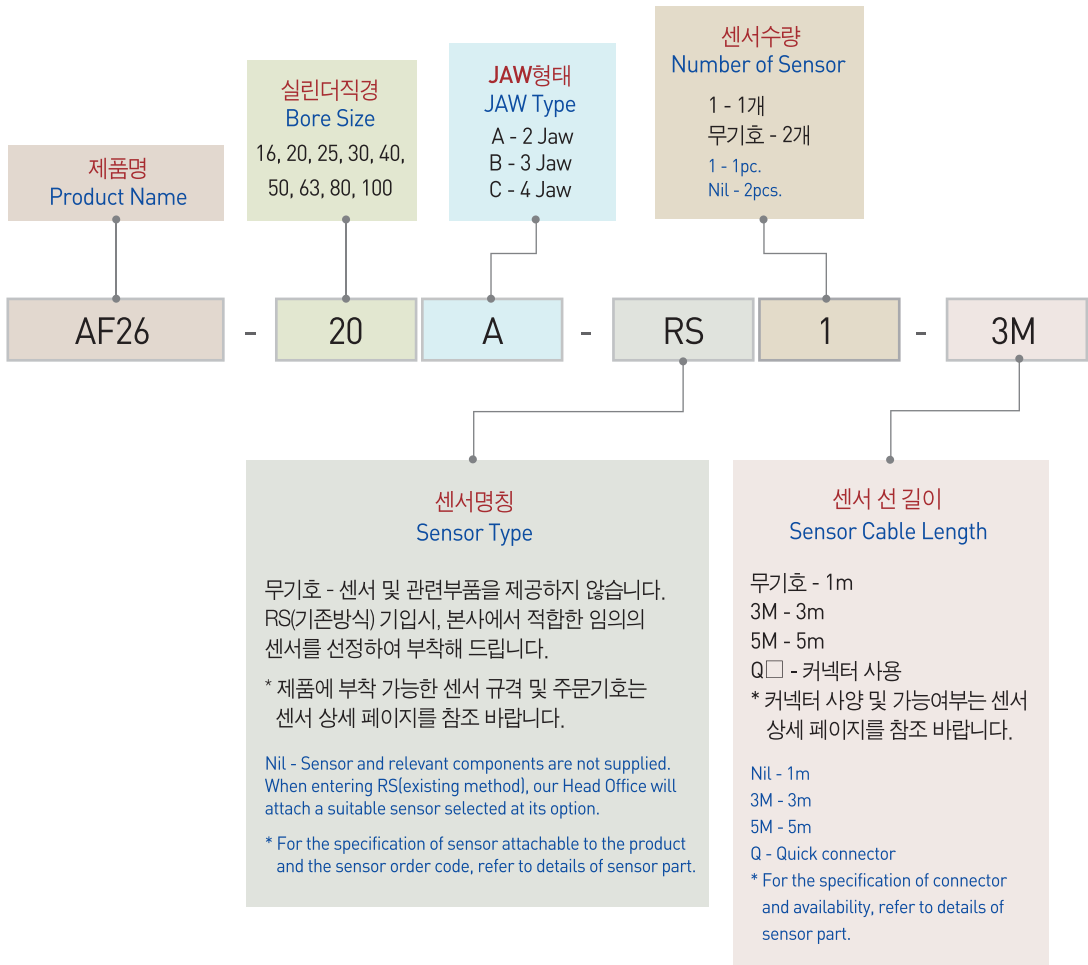

☐ 제품사양 (Specification)

※ 제품 중량은 B(3-Jaw) Type 기준입니다.
 ※ Weight is based on the B(3-Jaw) type.

P=공기압력(bar) , L=작동점까지의 거리(mm)
 P=Air Pressure(bar) , L=Exertion length(mm)

제품명칭 Products Name	AF26-16	AF26-20	AF26-25	AF26-30	AF26-40	단위 Unit
개폐범위 Stroke	6	8	12	12	20	mm
제품중량 Weight	0.21	0.32	0.51	0.63	1.59	kg
최대치구길이 Max. length attach	30	40	50	55	70	mm
배관접속구 Fitting size	M5	M5	M5	PF(G) 1/8	PF(G) 1/8	
파지력 : 열림시 Gripping force : Open	17.66P/(1+0.04L)	29.43P/(1+0.035L)	46.11P/(1+0.025L)	66.71P/(1+0.025L)	115.76P/(1+0.015L)	N
파지력 : 닫힘시 Gripping force : Close	13.73P/(1+0.04L)	22.56P/(1+0.035L)	37.28P/(1+0.025L)	49.05P/(1+0.025L)	87.31P/(1+0.015L)	N
1사이클당 공기소모량 Air consumption per cycle	1.1	2.9	6.9	9.7	30.8	cm ³
닫힘시/열림시 시간 Closing / Opening time	0.01/0.01	0.01/0.01	0.02/0.02	0.02/0.02	0.03/0.04	sec
반복정밀도 Repeat accuracy	0.03	0.03	0.03	0.03	0.03	mm
연속사용회수 Continuation usage amount	60	60	60	50	50	cpm
사용압력 Operating pressure	3~7					bar
주위온도 Ambient temperature	-5 to 60					℃
윤활 Lubrication	불필요 Needless					

제품명칭 Products Name	AF26-50	AF26-63	AF26-80	AF26-100	단위 Unit
개폐범위 Stroke	20	26	30	42	mm
제품중량 Weight	2.12	3.44	4.9	8.01	kg
최대치구길이 Max. length attach	80	100	130	150	mm
배관접속구 Fitting size	PF(G) 1/8	PF(G) 1/8	PF(G) 1/8	PF(G) 1/8	
파지력 : 열림시 Gripping force : Open	163.8P/(1+0.015L)	229.6P/(1+0.013L)	384.6P/(1+0.01L)	560.2P/(1+0.008L)	N
파지력 : 닫힘시 Gripping force : Close	135.4P/(1+0.015L)	194.2P/(1+0.013L)	338.4P/(1+0.01L)	384.6P/(1+0.008L)	N
1사이클당 공기소모량 Air consumption per cycle	48.1	109.1	219.9	442.5	cm ³
닫힘시/열림시 시간 Closing / Opening time	0.03/0.04	0.06/0.08	0.15/0.20	0.30/0.35	sec
반복정밀도 Repeat accuracy	0.03	0.03	0.03	0.03	mm
연속사용회수 Continuation usage amount	40	40	30	30	cpm
사용압력 Operating pressure	3~7				bar
주위온도 Ambient temperature	-5 to 60				℃
윤활 Lubrication	불필요 Needless				

반복정밀도 : 연속 100회 작동후 측정치
 After 100 consecutive strokes to end positions

- AF101
- AF02
- AF03
- AF04P
- AF105P
- AF06
- AF10
- AF13
- AF13C
- AF14
- AF15
- AF316
- AF17
- AF117
- AF19
- AF24
- AF26
- AF28D
- AF30
- AF30L
- AF30SP
- AF40
- AF46
- AF56N
- RAF56N
- MF16

작용점에서의 파지력 (Gripping Force From a Point of Action)

범례(Legend) : ■ 7[bar] ■ 5[bar] ■ 3[bar]

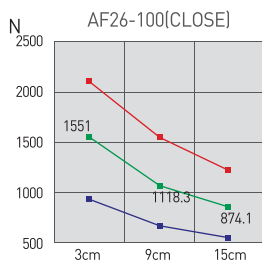
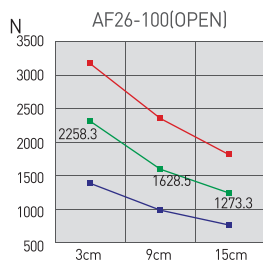
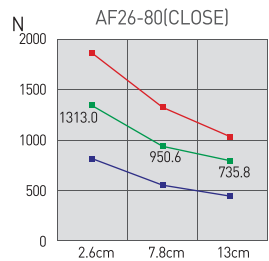
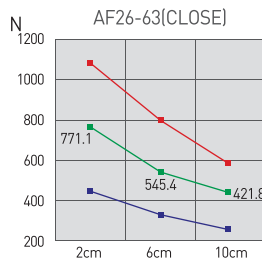
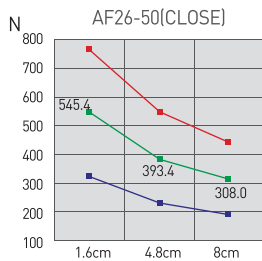
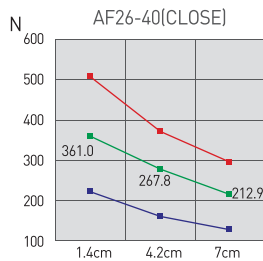
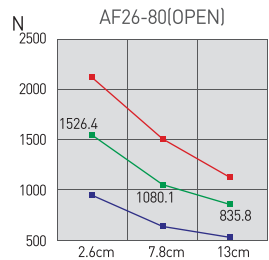
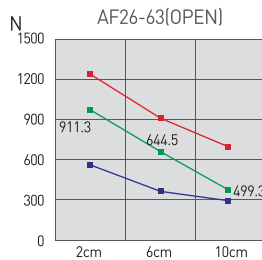
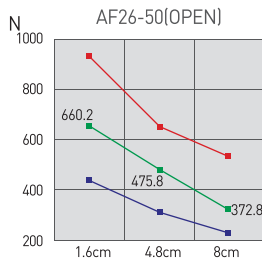
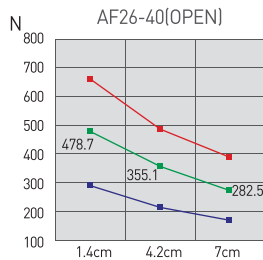
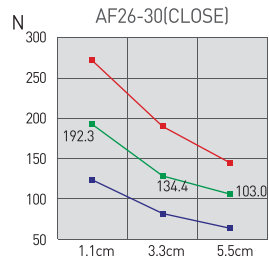
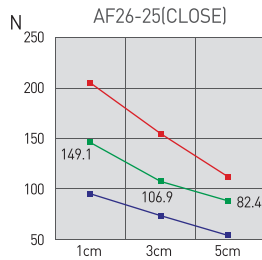
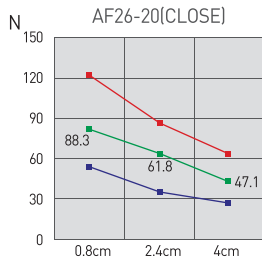
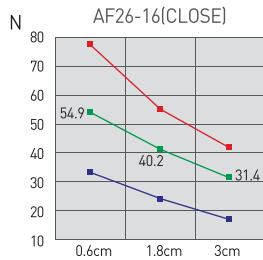
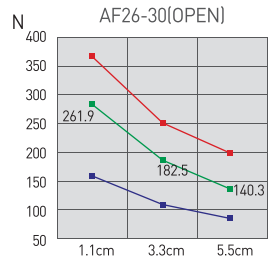
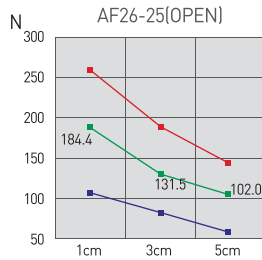
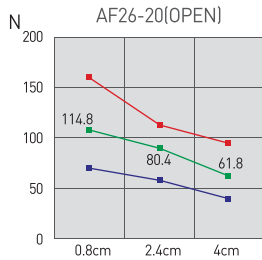
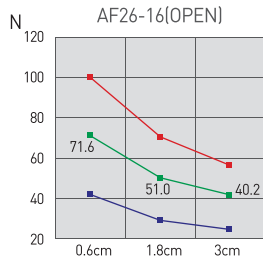

AF26-16

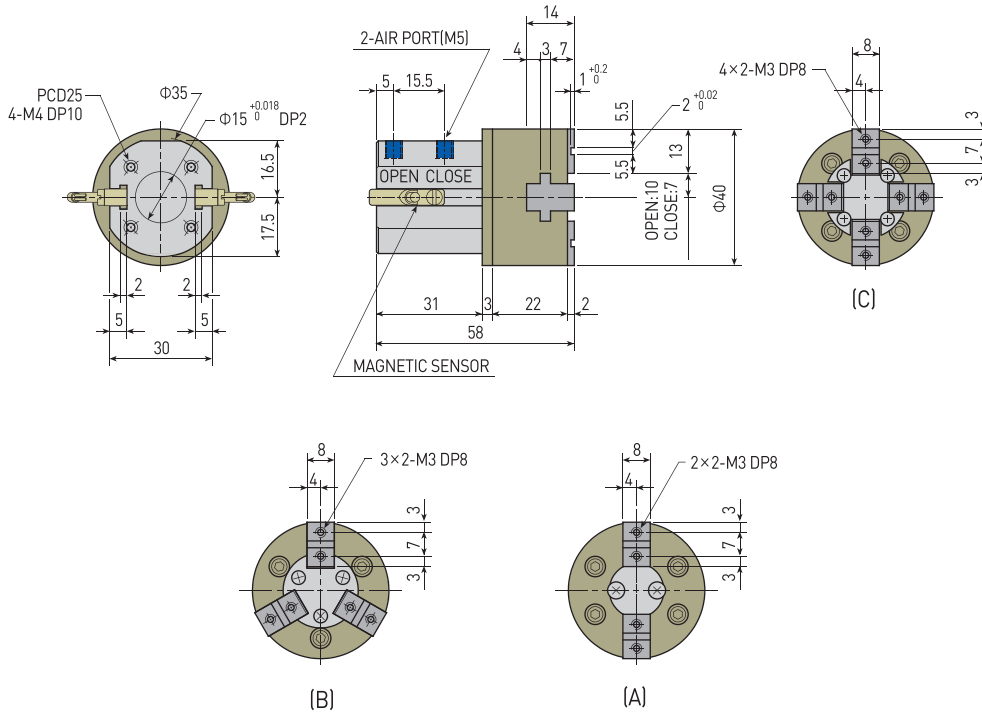

AF26-20

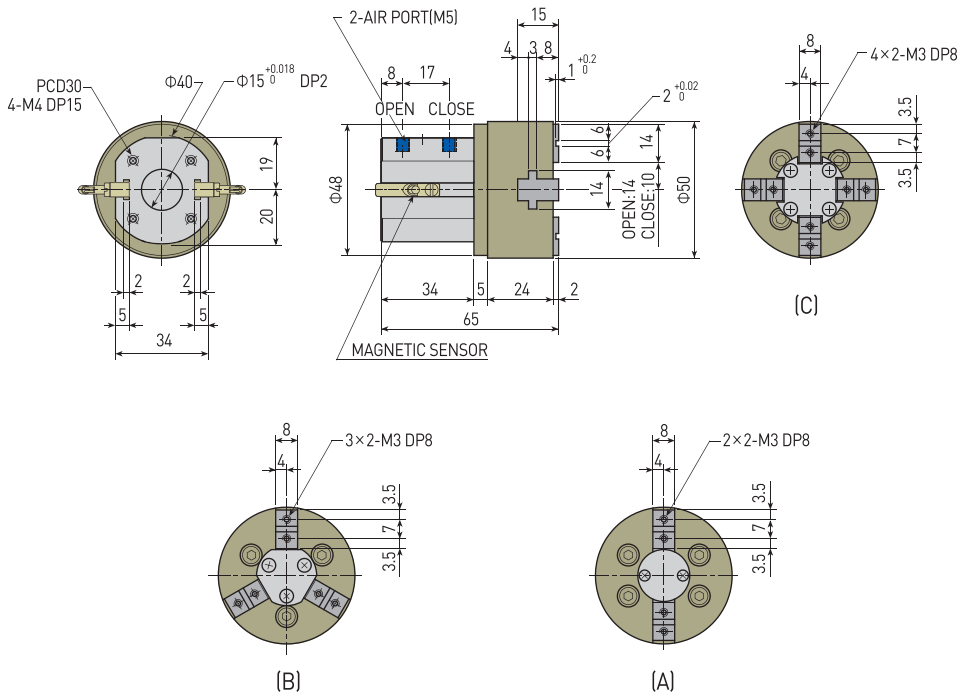

- AF101
- AF02
- AF03
- AF04P
- AF105P
- AF06
- AF10
- AF13
- AF13C
- AF14
- AF15
- AF316
- AF17
- AF117
- AF19
- AF24
- AF26**
- AF28D
- AF30
- AF30L
- AF30SP
- AF40
- AF46
- AF56N
- RAF56N
- MF16

AF26-25

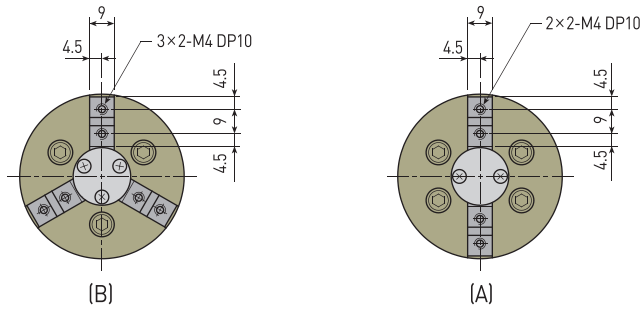
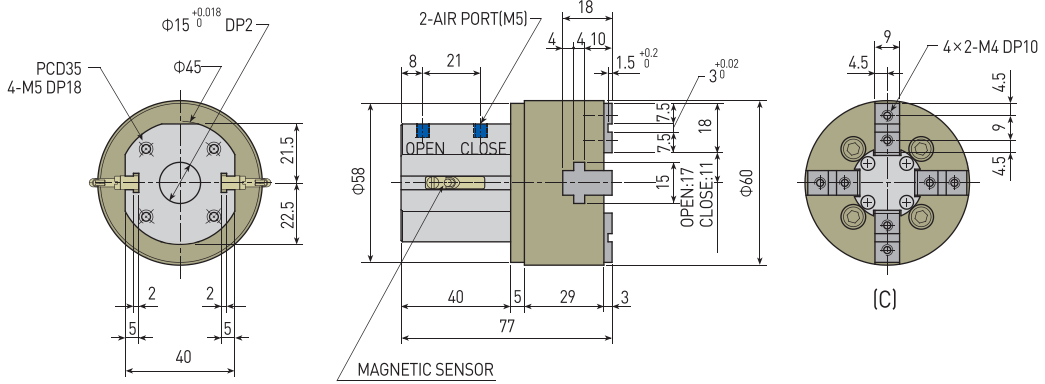

AF26-30

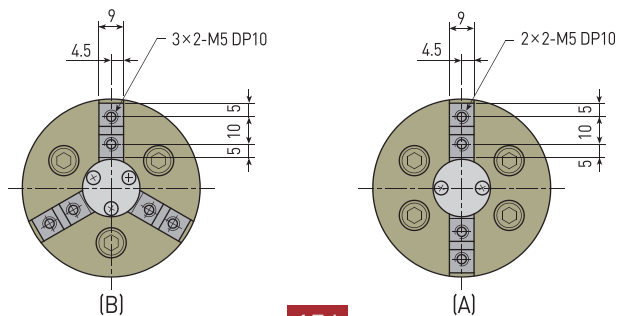
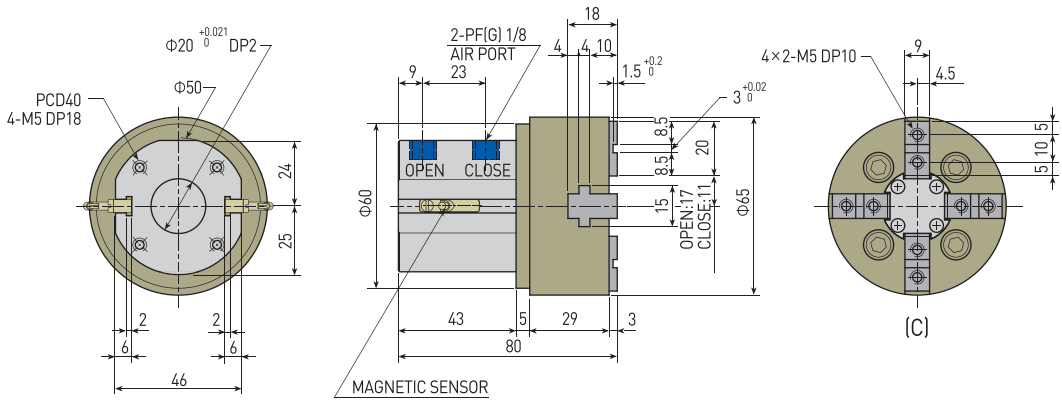

AF26-40

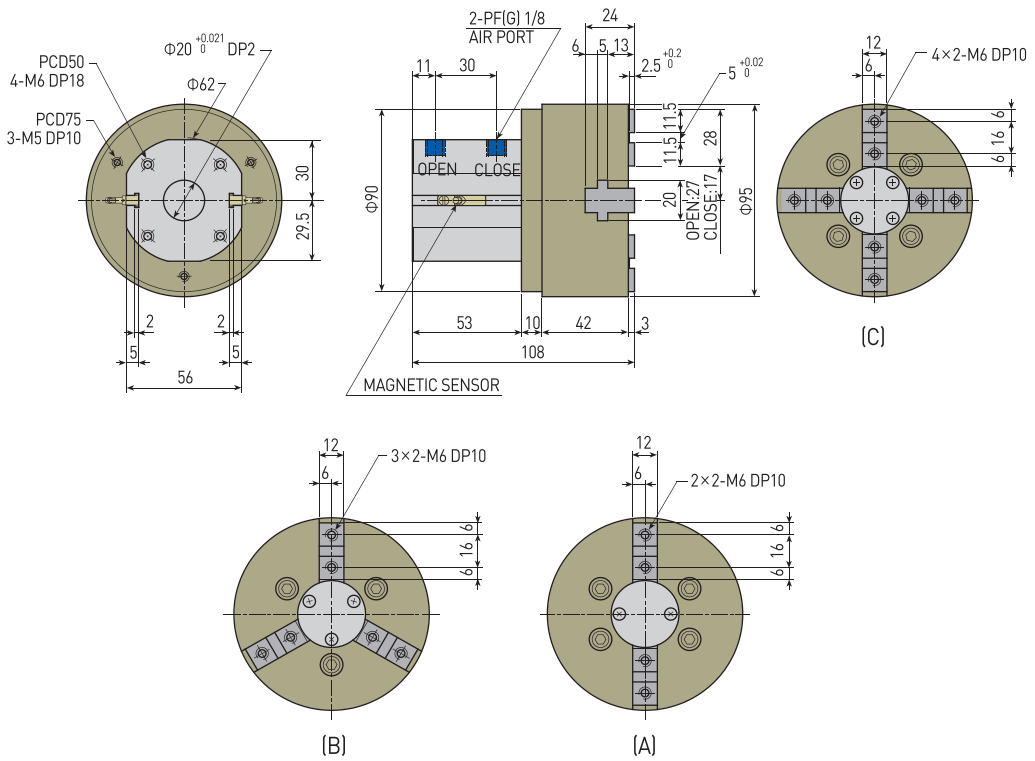

AF26-50

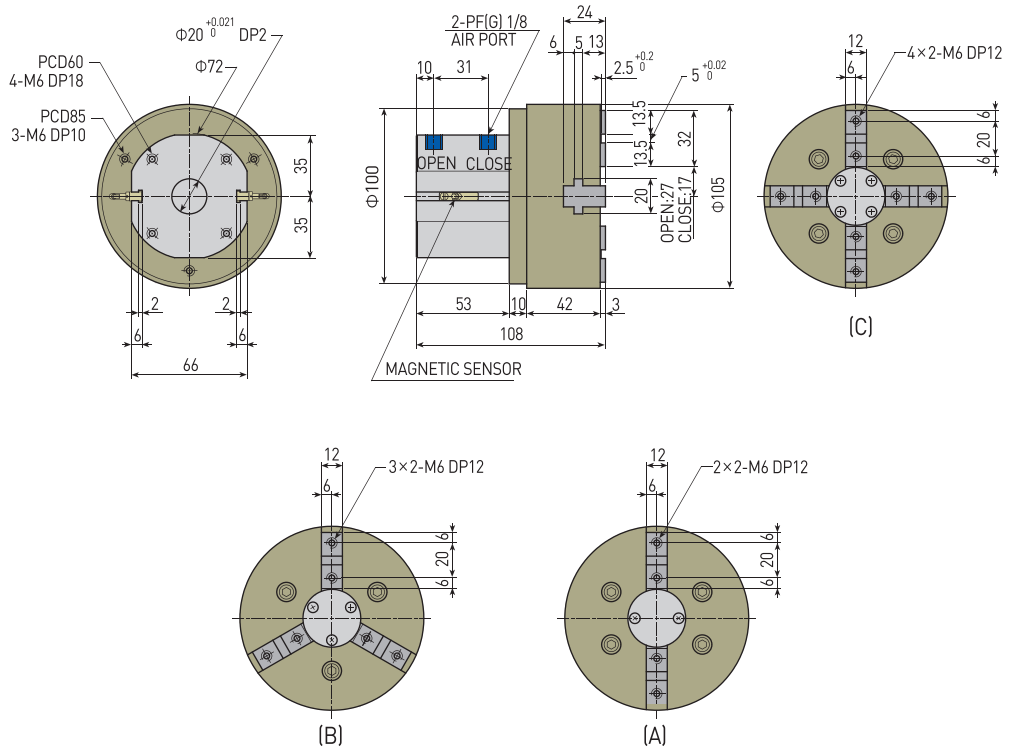

- AF101
- AF02
- AF03
- AF04P
- AF105P
- AF06
- AF10
- AF13
- AF13C
- AF14
- AF15
- AF316
- AF17
- AF117
- AF19
- AF24
- AF26
- AF28D
- AF30
- AF30L
- AF30SP
- AF40
- AF46
- AF56N
- RAF56N
- MF16

AF26-63

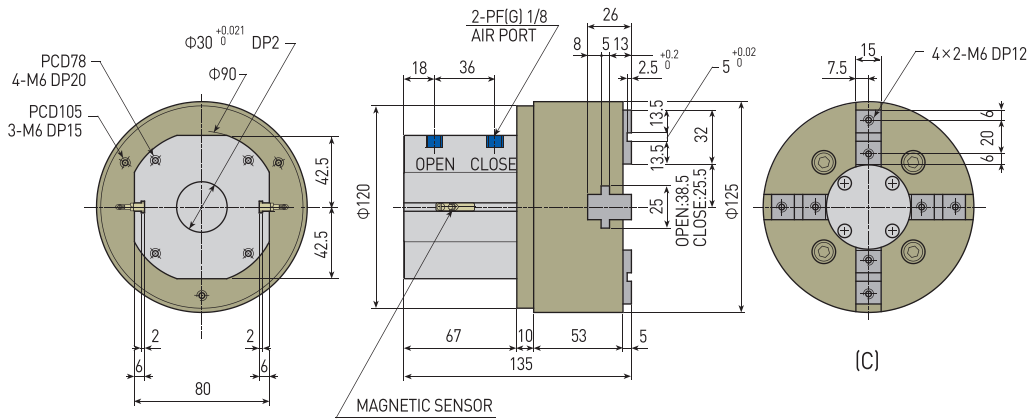

(B)

(A)

AF26-80

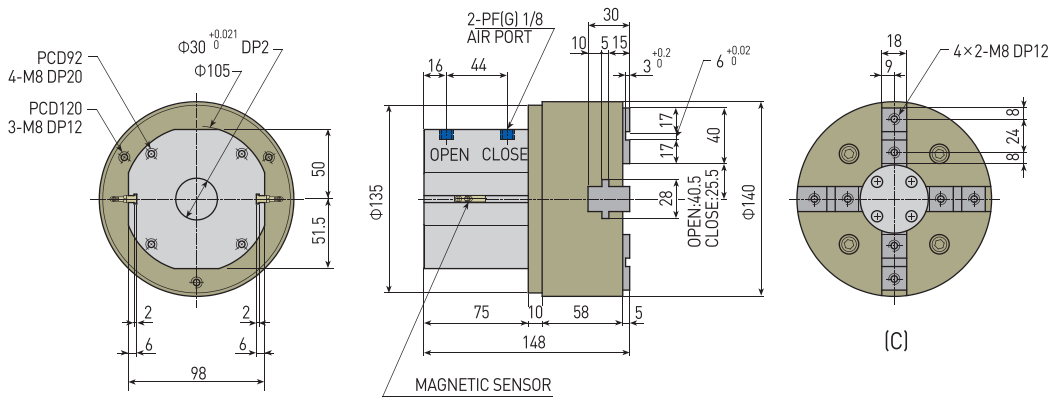

(B)

(A)

AF26-100

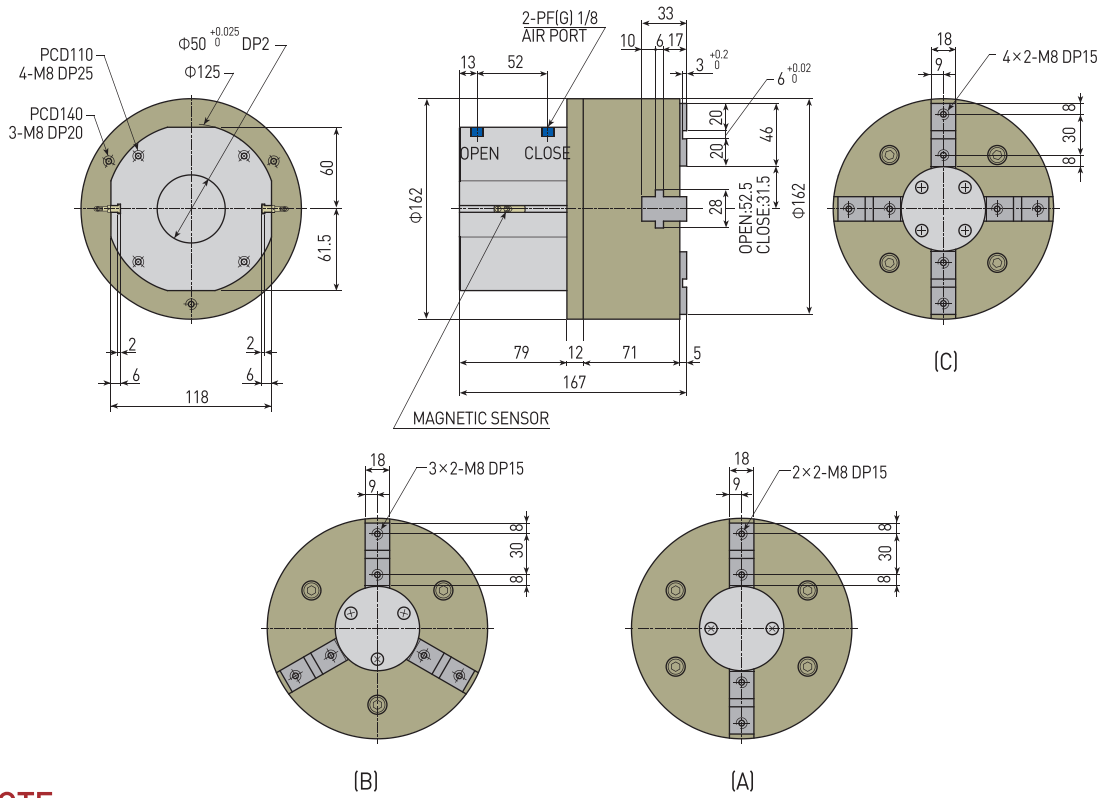

NOTE

- AF101
- AF02
- AF03
- AF04P
- AF105P
- AF06
- AF10
- AF13
- AF13C
- AF14
- AF15
- AF316
- AF17
- AF117
- AF19
- AF24
- AF26**
- AF28D
- AF30
- AF30L
- AF30SP
- AF40
- AF46
- AF56N
- RAF56N
- MF16